



# GENUINE FRONT UNDER SKIRT

## INSTALLATION AND USER'S INSTRUCTIONS

Thank you for purchasing a genuine Mazda accessory.  
Before removal and installation, be sure to thoroughly read these instructions.  
Please read the contents of this booklet in order to properly install and use the front under skirt. Your safety depends on it.  
Keep these instructions with your vehicle records for future reference.

### **WARNING**

- There are several  **WARNING** and  **CAUTION** sections in this booklet concerning safety when installing or removing the front under skirt. Always read and follow them in order to prevent injuries, accidents, and possible damage to the vehicle.

 **WARNING:** Indicates a situation in which serious injury or death could result if the warning is ignored.

 **CAUTION:** Indicates a situation in which bodily injury or damage to the vehicle could result if the caution is ignored.

- For areas indicating the tightening torque in this instruction manual, tighten to the specified torque using a torque wrench. For areas in which the tightening torque is indicated inside parentheses ( ), the tightening torque is indicated as a reference value, however tightening using a torque wrench is not necessary.
- Do not modify the front under skirt.
- Do not install the front under skirt. In any way other than described in the following instructions.
- If in any doubt, please ask your Mazda dealer to install the accessory in order to prevent errors in installation.
- If you have any questions about the use of the accessory, ask your Mazda dealer for proper advice before using it.
- Mazda and its suppliers are not responsible for injuries, accidents, and damage to persons and property that arise from the failure of the dealer or installer to follow these instructions.
- To ensure safety and reliability of the work, installation, removal and disposal work must be carried out by an Authorized Mazda Dealership.
- Be careful not to lose removed parts and be sure that they are kept free from scratches, grease or other dirt.

**PART NAME: FRONT UNDER SKIRT**

**PART NUMBER: QBMN 50 AH0**

**QBME 50 AH0**

**QBMR 50 AH0**

**VEHICLE: MAZDA3**

### **NOTE**

#### **To the dealer**

- Please turn over these instructions to the customer after installation.

#### **To the customer**

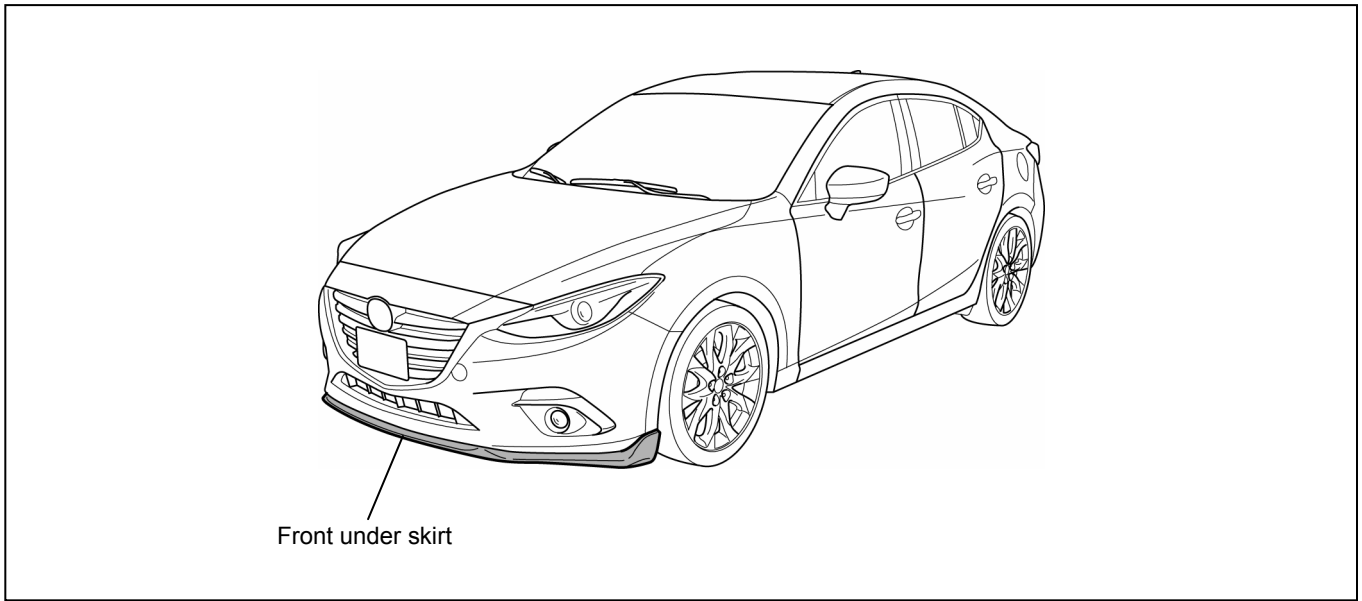

- Keep these instructions after installation. The instructions may be necessary for installing other optional parts or removal of this accessory.
- Should the vehicle or this accessory be resold, always leave these instructions with it for the next owner.

# 1. INSTALLATION VIEW

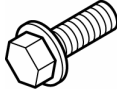

# 2. PARTS

- Before installation, verify that the kit includes all the following parts and that they are free of dirt, scratches, or damage.

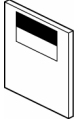
Part	Part name	Qty	Part	Part name	Qty
	Front under skirt	1		Bolt	2
	Nut	2		Template	1
	Installation and user's Instructions (Three languages: English, French and spanish)	1ea.			

Sold separately	Part name	Qty
	Primer (3M Promoter 4298)	1

## 3. BEFORE INSTALLATION

### ■ REQUIRED TOOLS

- ☆ Flathead screwdriver
- ☆ Socket wrench (8mm)
- ☆ Torque wrench
- ☆ Electric drill (3mm, 7mm)
- ☆ Cutter knife
- ☆ Punch
- ☆ Isopropyl alcohol (IPA)

### ⚠ WARNING

Park the vehicle on a flat, level surface, set the selector lever to P (AT vehicles) or the shift lever to 1st or R (MT vehicles), apply the parking brake and block the wheels so that the vehicle does not move during installation.

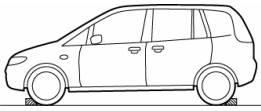

### ⚠ CAUTION

<p>Be sure to cover the vehicle body with protectors or mats to prevent stains, scratches and damage when removing/installing the vehicle parts</p>	<p>Using improper tools may cause damage and or broken parts. Use the correct tool for the job.</p>	<p>Put the removed parts and the parts in the kit on a protective sheet to prevent scratches.</p>	<p>Put the removed parts and the parts in the kit on a protective sheet to prevent scratches.</p>
<p>If there's dust, dirt or grease on the surface of adherend, the surface of two-sided tape will splotch and adhesive power of the tape will be reduced. It is required to wash the surface of the adherend before adhesion. Be sure to wash interior and exterior parts using IPA (isopropyl alcohol).</p>			
<p>IPA (Isopropyl alcohol)</p>			

### Advice

Refer to the Workshop Manual for removal and installation of vehicle parts.



## 4. FRONT UNDER SKIRT INSTALLATION

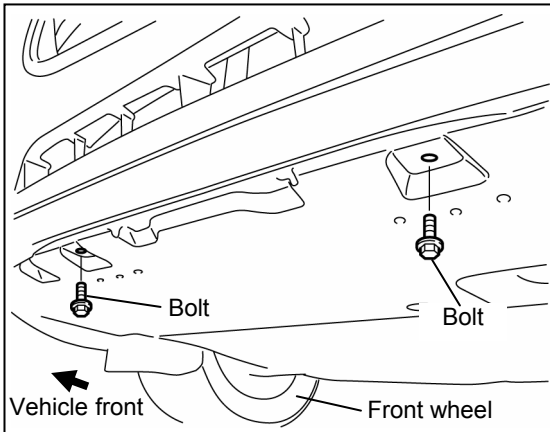

1. Remove the bolts (2) shown in the figure.

- The removed bolts are not reused.

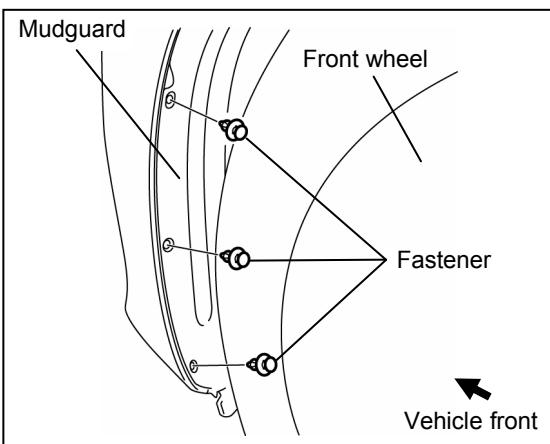

2. Remove the fastener (3) shown in the figure.

- The removed fasteners are reused.
- Perform the same procedure on the opposite side.

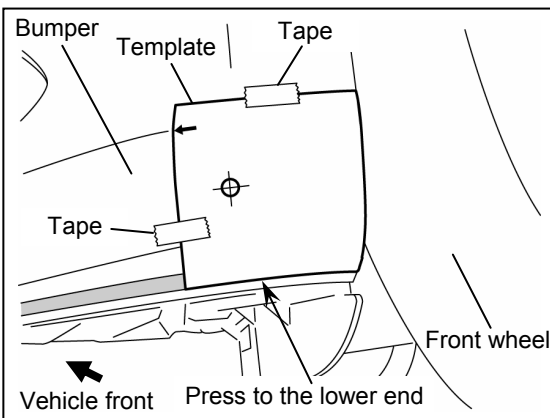

3. Adhere the template to the vehicle and tap a mark into the center of the hole position using a punch.

- Perform the same procedure on the opposite side.

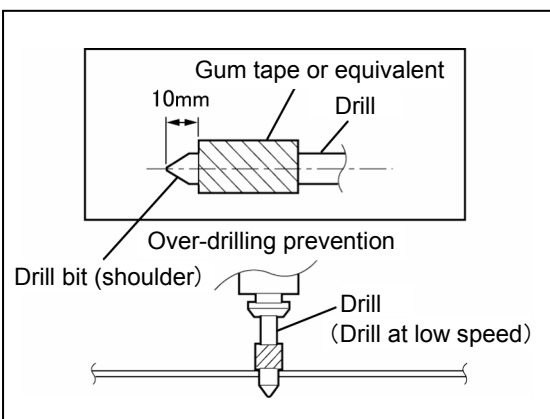

4. Wrap the drill bit with duct tape as shown in the figure.

5. Set the drill speed to low.

### ⚠ Caution

- Always use a drill with a rotation speed adjustment; otherwise the bumper may deform.
- Be careful when handling drill bit.
- To prevent scratching and over-drilling, always wrap the drill bit with duct tape.

6. Position the drill perpendicular to the bumper and drill a hole with a 3 mm diam. bit in the marked position first, then expand the hole diameter using a 7mm diam. bit.

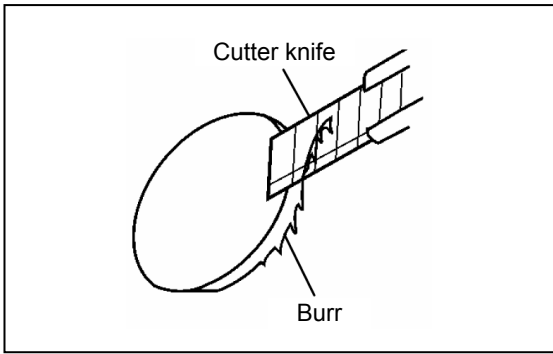

7. Remove burrs from the drilled holes using a utility knife.

**⚠ Caution**

- Make sure to remove burrs from the surface so that the bumper surface is smooth.

8. Clean the double-sided adhesive tape adhesion surface using IPA (isopropyl alcohol).

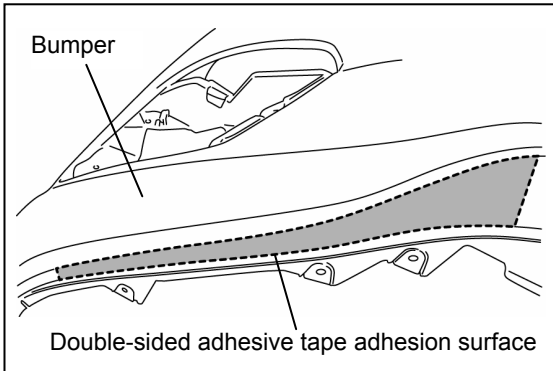

9. Apply the pack primer to the unpainted bumper surface area where the double-sided adhesive tape is to be adhered.

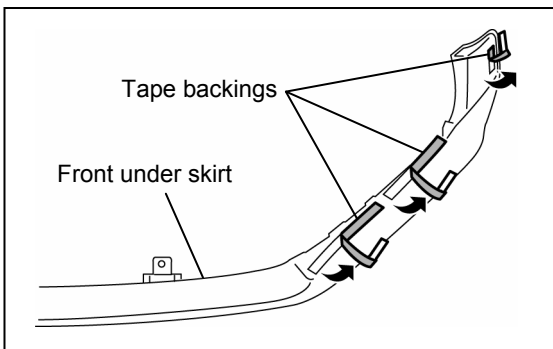

10. Peel back the paper backings on the front under skirt about halfway.

- Perform the same procedure on the opposite side.

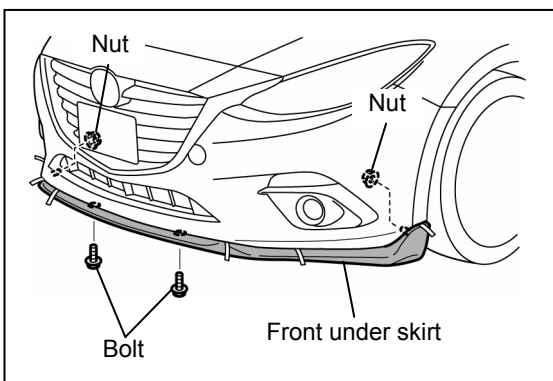

11. Attach the front under skirt to the vehicle and temporarily install it using the nuts (2) and bolts (2).

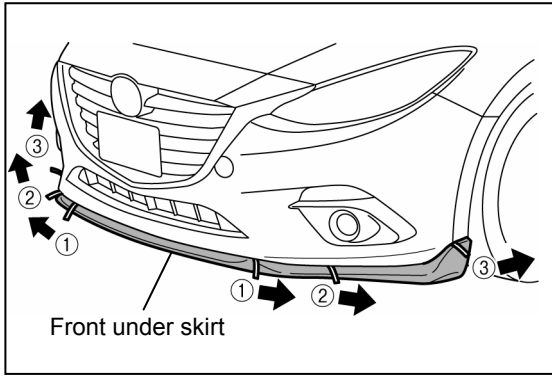

12. Peel off the paper backings of the double-sided adhesive tape in the direction of the arrows, and press the tape against the body with sufficient force.

**ADVICE**

- Do not remove the accessory once it has been affixed; otherwise it will lose adhesive strength.
- After installing the front under skirt, do not wash the vehicle for a period of 24 hours.

13. Tighten the nuts (2) and bolts (2).

**Bolt tightening torque: (0.8—1.2 N·m)**

**Nut tightening torque: (0.8—1.2 N·m)**

## 5. INSPECTION ITEMS AFTER INSTALLATION

1. Make sure that there are no gaps.

- If there are any gaps, loosen the nuts and bolts (2 locations) and then retighten them while pressing the front under skirt against the front bumper.

2. Inspect the installation of the installed bolts and nuts.

## 6. TO THE CUSTOMER

Please pay attention to the following with regard to handling (maintenance) of the front under skirt.

- If the hard plastic parts come into contact with gasoline, oil, refrigerant, or battery fluid, it could cause discoloration, staining or damage. Use a soft, clean cloth to wipe such fluids off immediately.
- Depending on the type of high pressure car washer used, the water for washing may be high temperature and/or under high pressure. Be careful when using pressurized water from a car washer nozzle. If the nozzle is too close or water pressure is applied for long periods, it may cause deformation or damage to the hard plastic parts.
- Do not use electric or air tools to apply wax or compound (polishing powder). Otherwise, friction heat will be generated causing deformation or damage to the hard plastic parts.
- If the vehicle height is lowered due to the vehicle being at maximum passenger or cargo capacity, decrease the vehicle speed when parking on a road shoulder or entering/leaving a road shoulder or bump. Otherwise, the front under skirt could be damaged.

Date _____ , _____ , _____				
VIN _____				
Approved		Checked		Person in charge

<b>INSTALLATION INSPECTION SHEET</b>	<b>MAZDA3</b>	<b>Front under skirt</b>
		<b>QBMN 50 AH0</b> <b>QBME 50 AH0</b> <b>QBMR 50 AH0</b>

Perform the following inspections

**Inspection items after installation**

Check

- Verify the fitting between the vehicle part and the installed part, and inspect for damage or dirt.